

# **LAARS® MINI-THERM®**

Gas-Fired Residential  
Hydronic Boilers



**NOW WITH AUTO SET POINT  
AND OUTDOOR RESET INCLUDED!**

**LAARS®** 

**Heating Systems Company**

A subsidiary of **BRADFORD WHITE®** Corporation

# **THE COMPACT MINI-THERM™** **FOR SUPERB HOME HEATING COMFORT**



**LAARS MINI-THERM** gas-fired residential hydronic boiler is an ideal heating appliance that can reduce homeowners heating costs and has plenty of capacity to keep even the largest home comfortable on the coldest days. The compact boiler has a low-mass heat exchanger and a super-quick heating response to meet your residential application requirements. The Mini-Therm comes in two varieties, JVS-spark ignition and the JVH-hot surface ignition with induced draft. Each is designed to meet specific installation needs while being energy efficient and light on your budget. Natural or propane gas models are available.

## **UNIQUE HEAT EXCHANGER DESIGN**

Laars engineers developed a copper tube heat exchanger with small cast iron "wet-walls" to combine the benefits of both material properties while removing their potential drawbacks. Features include a low-mass heat exchanger and quick heating response to meet residential application requirements, ideal for new homes or replacement boilers. Heat exchanger reliability has been field proven over many years, be assured that the Mini-Therm will provide heating comfort and dependability.

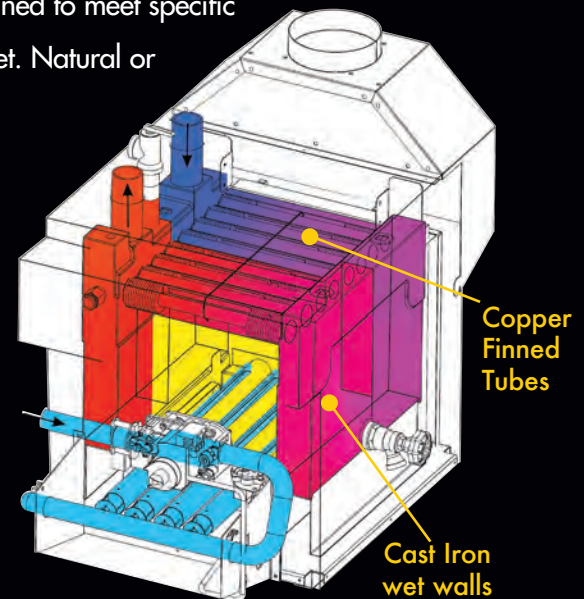

## **COMBINED BENEFITS OF COPPER AND CAST IRON**

- **Heat is transferred up to 7 times faster via copper than cast iron.**
- **Less copper is needed to heat the same amount of water as compared to full cast iron boilers, resulting in a smaller and lighter boiler.**
- **The small cast iron wet walls act as mini heat sinks to hold just enough heat to help minimize boiler short cycling. This helps increase efficiency and boiler life.**

**THE MINI-THERM IS THE PERFECT BALANCE OF TECHNOLOGY, EFFICIENCY AND VALUE.**

**LAARS®**   
**Heating Systems Company**

A subsidiary of **BRADFORD WHITE®** Corporation

# LAARS® MINI-THERM JVS



Extremely popular with homeowners, the JVS model offers an attractive and easy-to-service jacket. Well-known for their economy, a built-in draft diverter and automatic vent damper are included to stop your valuable fuel payments from disappearing up the chimney in wasted heat.

The durable Mini-Therm JVS is the smart choice for your home heating needs.

## Sizing Data

Size	Input Natural & Propane		Heating Capacity				AFUE	
			Nat. Gas		Pro. Gas		Nat. Gas	Pro. Gas
	MBH	kW	MBH	kW	MBH	kW	%	%
50	50	14.7	43	12.6	43	12.6	85.0	85.4
75	75	22.0	64	18.8	64	18.8	85.0	85.2
100	100	29.3	85	24.9	85	24.9	85.0	85.0
125	125	36.6	106	31.1	106	31.1	85.0	85.0
160	160	46.9	136	39.8	136	39.8	85.0	85.0
225	225	65.9	191	56.0	190	55.7	85.0	85.0

## Dimensional Data

Size	A		B		C		D		E		F		Weight	
	in.	cm	in.	cm	in.	cm	in.	cm	in.	cm	in.	cm	lbs.	kg
50	13 <sup>3</sup> / <sub>8</sub>	34	27 <sup>3</sup> / <sub>4</sub>	71	18	46	21 <sup>3</sup> / <sub>4</sub>	55	26 <sup>1</sup> / <sub>2</sub>	67	107 <sup>1</sup> / <sub>2</sub>	148	120	54
75	13 <sup>3</sup> / <sub>8</sub>	34	27 <sup>3</sup> / <sub>4</sub>	71	18	46	21 <sup>3</sup> / <sub>4</sub>	55	27 <sup>1</sup> / <sub>2</sub>	70	112 <sup>1</sup> / <sub>2</sub>	155	126	57
100	16 <sup>7</sup> / <sub>8</sub>	43	28 <sup>3</sup> / <sub>4</sub>	73	18	46	22 <sup>3</sup> / <sub>4</sub>	58	27 <sup>1</sup> / <sub>2</sub>	70	112 <sup>1</sup> / <sub>2</sub>	155	134	61
125	16 <sup>7</sup> / <sub>8</sub>	43	28 <sup>3</sup> / <sub>4</sub>	73	18	46	22 <sup>3</sup> / <sub>4</sub>	58	27 <sup>1</sup> / <sub>2</sub>	70	112 <sup>1</sup> / <sub>2</sub>	155	138	63
160	20 <sup>3</sup> / <sub>8</sub>	52	28 <sup>3</sup> / <sub>4</sub>	73	18	46	22 <sup>3</sup> / <sub>4</sub>	58	27 <sup>1</sup> / <sub>2</sub>	70	112 <sup>1</sup> / <sub>2</sub>	155	164	74
225	25 <sup>1</sup> / <sub>2</sub>	65	31 <sup>1</sup> / <sub>2</sub>	80	20	51	23 <sup>3</sup> / <sub>4</sub>	63	27 <sup>1</sup> / <sub>2</sub>	70	112 <sup>1</sup> / <sub>2</sub>	155	181	82

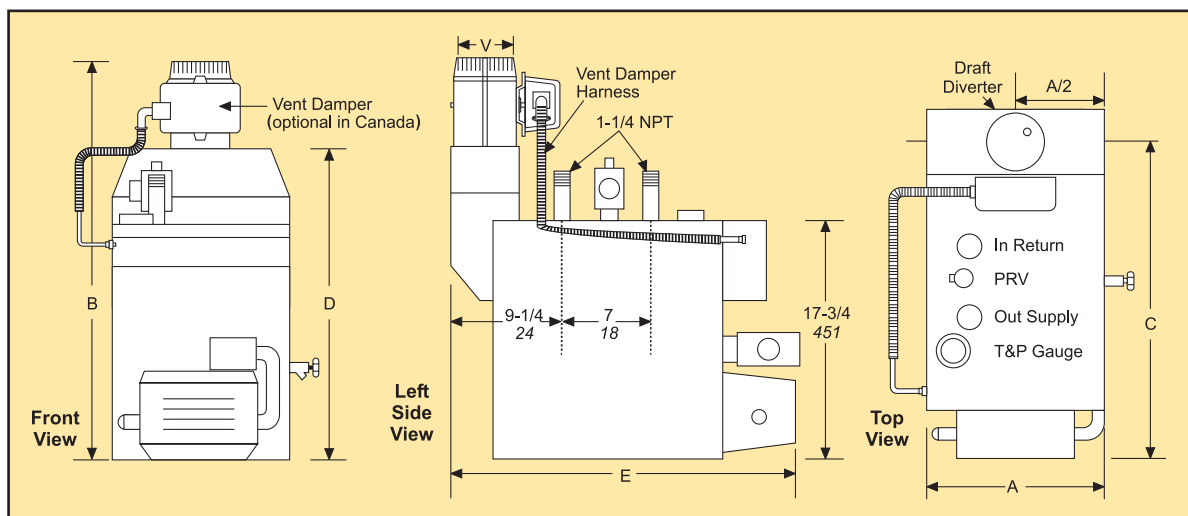

# LAARS® MINI-THERM JVH



Mini-Therm JVH uses an induced draft system with a gravity operated vent damper. The induced draft system allows the JVH to be installed where side-wall or chimney venting is needed. A hot surface ignition system (HSI) is used to operate all six sizes in single stage, on/off firing modes. Compact models are also easy to install, operate and maintain.

## Sizing Data

Size	Input Natural & Propane		Heating Capacity				AFUE	
			Nat. Gas		Pro. Gas		Nat. Gas	
	MBH	kW	MBH	kW	MBH	kW	%	%
50	50	14.7	41	12.0	42	12.3	83.4	84.0
75	75	22.0	62	18.2	63	18.5	83.2	84.0
100	100	29.3	82	24.0	83	24.3	82.4	84.0
125	125	36.6	102	29.9	103	30.2	82.4	82.8
160	160	46.9	131	38.4	132	38.7	82.3	82.4
225	225	65.9	184	53.9	187	54.8	82.2	83.2

## Dimensional Data

Size	A		B		C		Weight	
	in.	cm	in.	cm	in.	cm	lbs.	kg
50	13 <sup>3</sup> / <sub>8</sub>	34	3 <sup>1</sup> / <sub>8</sub>	8	2 <sup>7</sup> / <sub>8</sub>	7	160	73
75	13 <sup>3</sup> / <sub>8</sub>	34	2 <sup>1</sup> / <sub>4</sub>	6	2	5	165	75
100	16 <sup>7</sup> / <sub>8</sub>	43	5 <sup>3</sup> / <sub>4</sub>	15	2 <sup>7</sup> / <sub>8</sub>	7	180	82
125	16 <sup>7</sup> / <sub>8</sub>	43	5 <sup>1</sup> / <sub>2</sub>	14	2	5	185	84
160	20 <sup>3</sup> / <sub>8</sub>	52	7 <sup>1</sup> / <sub>4</sub>	19	2	5	210	95
225	25 <sup>5</sup> / <sub>8</sub>	65	10	26	2	5	225	102

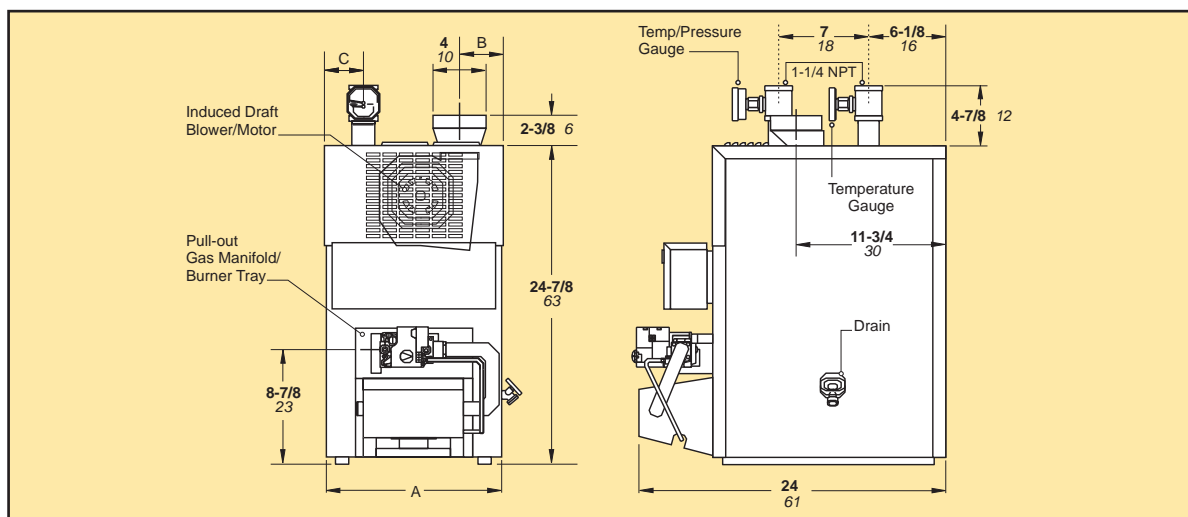

# LAARS<sup>®</sup> MINI-THERM ADVANCED CONTROLS

The Mini-Therm boiler operates at peak efficiency based on our latest controls upgrade that includes advanced programming to reduce gas consumption and minimize utility bills. This new control also makes the Mini-Therm an easier to install boiler, with a new auto set-point feature that automatically determines the boiler target temperature.

**Outdoor Reset with Auto Differential Control** – Outdoor reset continuously adjusts the boiler heat output to match outdoor conditions. The boiler control does this by reading the outdoor temperature and calculating if there will be a heavy demand or light demand on the boiler based on past history. The controls can compensate for a fast response (cold days) or slower response (warmer days) to reduce fuel use. It also makes it very easy to install since target temperature set points do not need to be setup, the boiler automatically knows what to do!

**Space Heating with Domestic Water Priority** – when an indirect water heater is installed with the Mini-Therm and there is a call for both space heating and domestic water heating the controls will make sure that the domestic water is heated first and then returns to heating the home. This ensures there will always be plenty of hot water at every point in a home.

***Mini-Therm boilers offer exceptional value with “high performance hydronics” that give customers the highest performance at the lowest cost. By far, Mini-Therm is the right solution for any size residential home heating system.***



The ingenious Laars-Stor™ water heaters are engineered to provide the highest hot water output at the lowest pressure drop of most any indirect fired water heater in the industry. Hot water from the Mini-Therm enters the coiled heat exchanger that sits inside the Laars-Stor tank. The heat from the boiler water is efficiently passed through the heat exchanger coil to the domestic water in the tank. The tank and boiler can be located very close to each other resulting in minimal space used. The Laars-Stor is packed with features to ensure many years of safe, hot water when you need it!





View our entire product line at [www.Laars.com](http://www.Laars.com)

**TED WHITNEY  
HEATING & AC  
INC.**  
**814-223-4009**



**LAARS**<sup>®</sup>   
**Heating Systems Company**  
 A subsidiary of **BRADFORD WHITE**<sup>®</sup> Corporation

**Customer Service and Product Support:** 800.900.9276 • Fax 800.559.1583

**Headquarters:** 20 Industrial Way, Rochester, NH, USA 03867 • 603.335.6300 • Fax 603.335.3355

9 Brigden Gate, Halton Hills, Ontario, Canada L7G 0A3 • 905.203.0600 • Fax: 905.636.0666

[www.Laars.com](http://www.Laars.com)